

**Faculty of Engineering & Technology**  
**Third Semester B.E. (Mechanical Engg.)/  
Power Engg. (C.B.S.) Examination**  
**KINEMATICS OF MACHINE**

Time : Three Hours]

[Maximum Marks : 80

**INSTRUCTIONS TO CANDIDATES**

- (1) All questions carry marks as indicated.
- (2) Solve **SIX** questions as follows :  
Question No. 1 **OR** Question No. 2  
Question No. 3 **OR** Question No. 4  
Question No. 5 **OR** Question No. 6  
Question No. 7 **OR** Question No. 8  
Question No. 9 **OR** Question No. 10  
Question No. 11 **OR** Question No. 12.
- (3) Due credit will be given to neatness and adequate dimensions.
- (4) Illustrate the answers with necessary figures/ drawings wherever necessary.
- (5) Retain the construction lines.
- (6) Use of drawing instruments is permitted.
- (7) Use of non-programmable calculator is permitted.
- (8) Assume suitable data wherever necessary.

1. (a) Differentiate between :

(i) Lower pair and higher pair. 2

(ii) Closed pair and unclosed pair. 2

(b) What do you mean by constrained motion? Explain successfully constrained motion with neat sketch. 4

(c) With the help of a neat sketch, show that the angle of return stroke is less than the forward stroke in a quick return mechanism. 5

OR

2. (a) Determine the mobility of the systems shown : 6

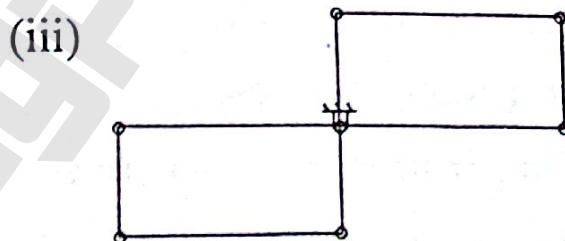
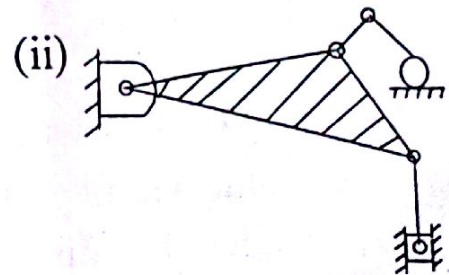
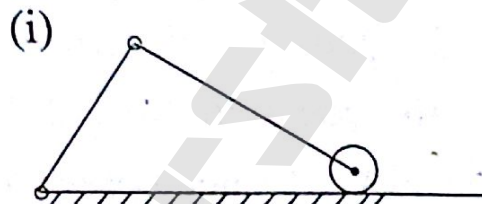

(b) With neat sketch show that Peaucellier mechanism is an exact straight line mechanism. 7

3. The crank AB of the mechanism shown in Fig. 3.1 is rotating with a speed of 30 rpm clockwise.

(i) Draw the velocity and acceleration diagrams.

10

(ii) Determine the angular velocity of link CDE and link DF.

2

(iii) Determine the linear acceleration of slider F and angular acceleration of link BC.

2

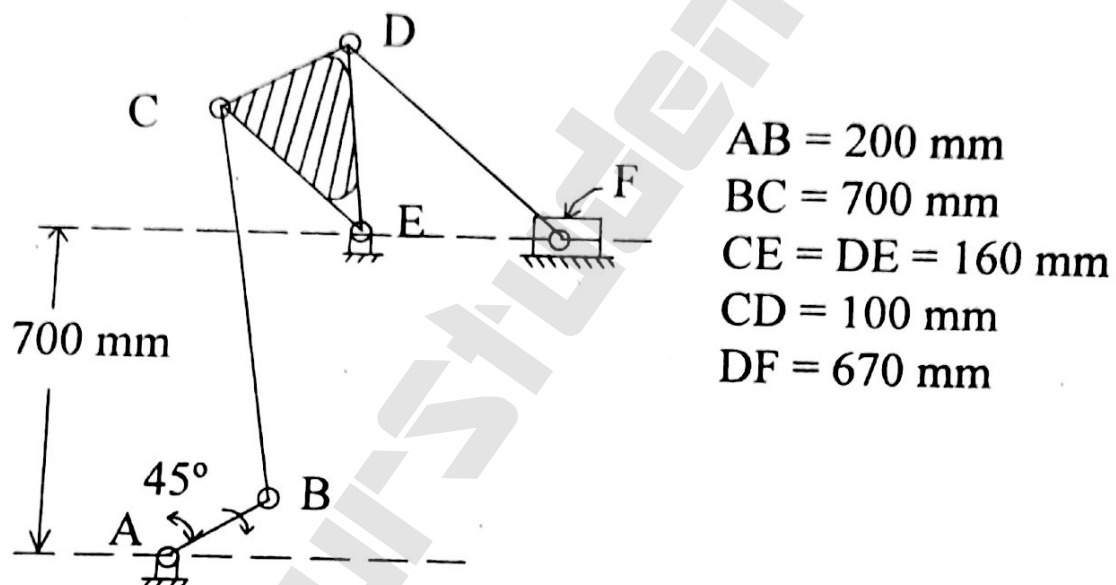

Fig. 3.1

OR

4. (a) What is Coriolis component of acceleration? How is the direction of this acceleration determined?

5

- (b) In a slider-crank mechanism, the lengths of the crank and the connecting rod are 200 mm and 800 mm respectively. Locate all the I-centres of the mechanism for the position of the crank when it has turned  $30^\circ$  from inner dead centre. Also find the velocity of the slider and the angular velocity of the connecting rod if crank rotates at 40 rad/sec clockwise. 9
5. The following data refers to a cam in which the follower moves with SHM during ascent while it moves with uniformly accelerated and decelerated motion during descent (parabolic) :
- Least radius of cam = 50 mm  
 Angle of ascent =  $48^\circ$   
 Dwell between ascent and descent =  $42^\circ$   
 Angle of descent =  $60^\circ$   
 Dwell for remaining cycle  
 Lift of follower = 40 mm  
 Roller diameter = 30 mm; off-set of line of action of follower and cam axis is 20 mm.
- (i) Draw the displacement diagram 3  
 (ii) Draw the cam profile. 8  
 (iii) Find maximum velocity and acceleration of the follower during descent if cam speed is 360 r.p.m. 2

**OR**



6. Draw the cam profile for cam with roller reciprocating follower. The axis of the follower passes through the axis of the cam. Particulars of the cam and follower motion are as following :

Roller diameter = 15 mm

Minimum radius of cam = 25 mm

Total lift = 35 mm

The cam has to lift the follower with SHM during  $180^\circ$  of cam rotation, then allow the follower to drop suddenly half way, and further return with uniform velocity during remaining  $180^\circ$  of cam rotation :

- (i) Determine the displacement diagram 3
  - (ii) Draw cam profile 7
  - (iii) Determine maximum velocity and acceleration during outstroke. 3
7. (a) Two gears 30 and 40 involute teeth respectively are in mesh. Pressure angle is  $20^\circ$ , module pitch is 12 mm. The length of contact on each side of the pitch point is half the maximum possible length. Find the height of addendum for each gear wheel. Also determine the contact ratio. 7

- (b) Two spiral gears in mesh have the following data :

$\tan^{-1} \mu = 6^\circ$  ; Normal pitch = 19 mm;

Shaft angle =  $50^\circ$  ; Speed ratio = 2

Approx centre distance = 375 mm.

For the same spiral angle for driver and driven :

- |                                   |   |
|-----------------------------------|---|
| (i) number of teeth on each wheel | 3 |
| (ii) exact centre distance        | 2 |
| (iii) efficiency of drive.        | 2 |

**OR**

8. (a) In a reverted epicyclic train shown in Fig. 8.1 the arm F carries two wheels A and D and a compound wheel B-C. Wheel A meshes with wheel B and wheel D meshes with C. The number of teeth on A = 40; B = 24 and C = 36.

Determine speed of D when A is fixed and arm F rotates at 300 rpm counter clockwise. 8

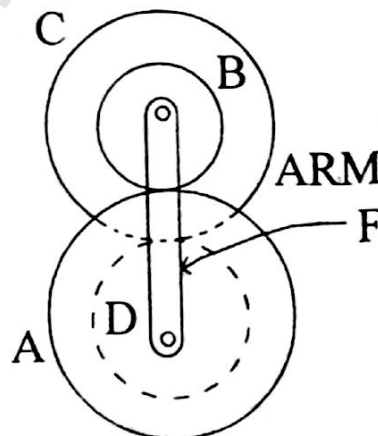

**Fig. 8.1**

- (b) (i) Explain how involute gear tooth profile satisfy law of gearing. 4
- (ii) What are the advantages of involute profile over cycloidal profile ? 2
9. (a) What is Chebychev's spacing ? What is its significance ? 5
- (b) Design a four link mechanism analytically to co-ordinate three positions of the input and output links as follows :
- $\theta_1 = 20^\circ \phi_1 = 35^\circ$
- $\theta_2 = 35^\circ \phi_2 = 45^\circ$
- $\theta_3 = 50^\circ \phi_3 = 60^\circ$ . 8

**OR**

10. (a) For designing a mechanism, explain :
- (i) Precision or accuracy points
- (ii) Structural error. 5
- (b) Design a four link mechanism to coordinate three position of input and output links for the following angular displacements using relative pole method :
- $\theta_{12} = 50^\circ \phi_{12} = 40^\circ ; \theta_{13} = 70^\circ \phi_{13} = 75^\circ$ . 8
11. (a) A multi-plate disc clutch transmits 55 kW power at 1800 r.p.m. Coefficient of friction for the surfaces is 0.1. Axial intensity of pressure is not to exceed 160 kN/m<sup>2</sup>. The internal radius is 80 mm and is 0.7 times the external radius. Find the number of plates needed to transmit required torque. 6

- (b) What are Dynamometer ? Discuss the working of Prony Brake Dynamometer with the help of neat sketch. 7

**OR**

12. (a) What are uniform pressure theory and uniform wear theory ? Deduce the expressions for the friction torque considering both the theories for a flat collar. 7
- (b) Ref. Fig. 12.1. A 70 cm brake drum has a contact angle  $40^\circ$ . It sustains 200 N-m of torque at 50 rpm. For coefficient of friction 0.3, determine :
- (i) total normal force on the shoe;
  - (ii) force to be applied for clockwise rotation;
  - (iii) dimension C, required to make the brake self locking;
  - (iv) rate of heat generated. 6

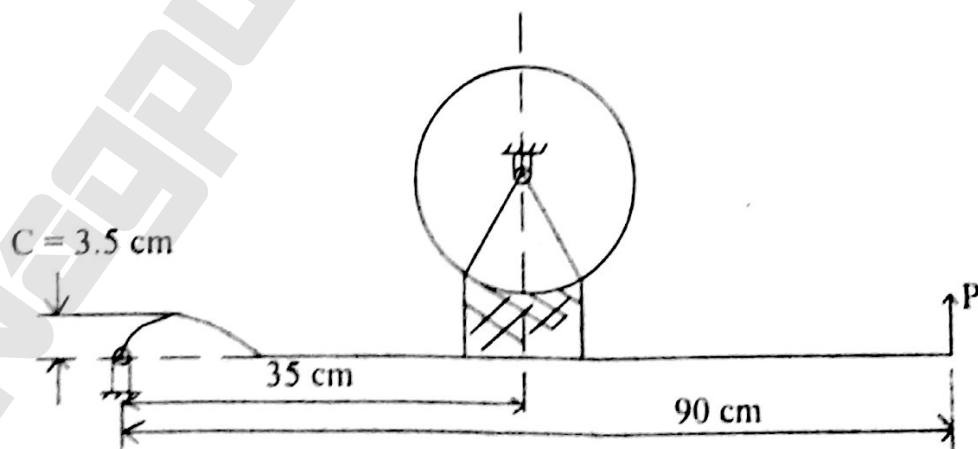

**Fig. 12.1**