

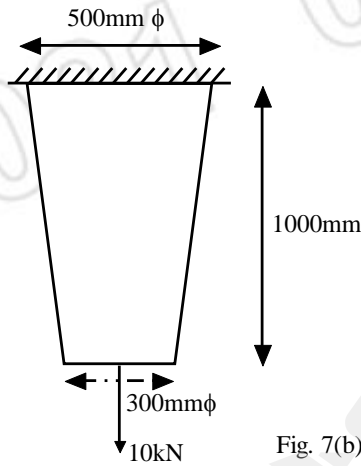

- Notes :
1. All questions carry marks as indicated.
  2. Solve Question 1 OR Questions No. 2.
  3. Solve Question 3 OR Questions No. 4.
  4. Solve Question 5 OR Questions No. 6.
  5. Solve Question 7 OR Questions No. 8.
  6. Solve Question 9 OR Questions No. 10.
  7. Solve Question 11 OR Questions No. 12.
  8. Assume suitable data whenever necessary.
  10. Illustrate your answers whenever necessary with the help of neat sketches.
  11. Use of non programmable calculator is permitted.
  12. Use of Design data book is permitted.

1. a) Differentiate between conventional design and CAD design. 4  
 b) Write Bresenham's algorithm for line generation for slope less than one [ $m < 1$ ]. Using the algorithm generate line from [5, 8] and [9, 11]. 9
2. a) Compare raster scan and vector scan displays. 4  
 b) Write midpoint algorithm for circle generation in first quadrant/octant. Using the algorithm draw a circle of radius 4 unit in 1<sup>st</sup> quadrant or octant. 9
3. a) Find the co-ordinate of figure bounded by (1, 4); (4, 1); (7, 4); (4, 7) when reflected along the line  $y=2x+8$  and sheared by 2 units in x-direction. 7  
 b) A rectangle A (4, 4); B (8, 4); C (8, 8); D (4, 8) is scaled by 1.5 units in y-direction about its center point. Further it is rotated about its center point by 90° in CCW direction. Find the final position of rectangle. 7
4. a) Write the 3-Dimensional concatenation matrix for rotation about an arbitrary axis. 7  
 b) A tetrahedron is having vertices (6, 6, 0); (14, 6, 0); (10, 13, 0) and (10, 13, 7.75) is scaled by 1.5 unit in x, y and z direction respectively find the final position of tetrahedron. 7
5. a) Explain with suitable example how CSG model can be created using set theory. 6  
 b) Explain in brief the mating relationship or constraints with the help of example explain how mating relations are used in 3D Assembly modeling. 7
6. a) The co-ordinate of four control points of curve is given by  $B_0 [3, 4]$ ;  $B_1 [6, 6]$ ;  $B_2 [12, 6]$ ;  $B_3 [15, 3]$ . Find the equation of resulting Bezier curve. Also find the co-ordinate of points lying on curve at  $t = 0, 0.3, 0.5, 0.8, 1$ . 8  
 b) Explain in brief B-spline curve. 5

7. a) Enlist the various types of elements used in FEM along with their characteristics. 4
- b) Fig. 7 (b) shows a taper bar subjected to point load of intensity 10kN at its free end, along with self weight. Take 9  
 $E = 200 \text{ GPa}$ ; density =  $\rho = 86 \times 10^{-6} \text{ N/mm}^3$ .  
 Determine the deflection at free end and stresses and support reaction



8. For the composite element shown below in fig (8) calculate the nodal displacement, stresses and reactions. 13

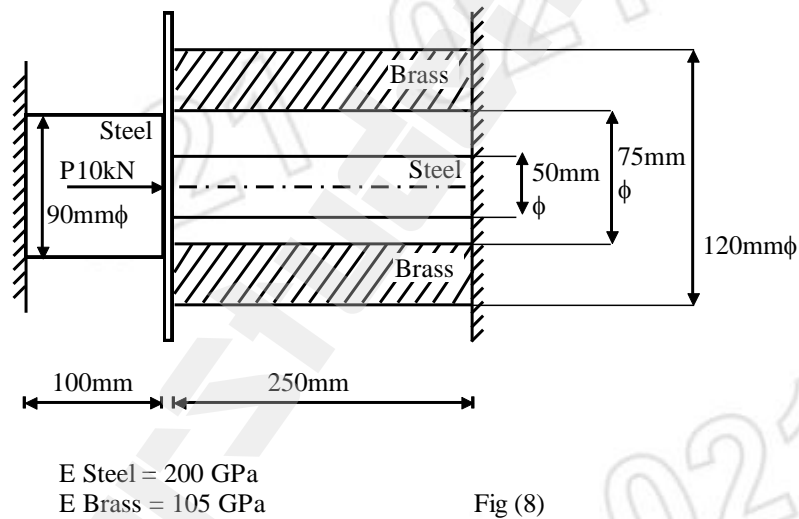

9. A truss shown in fig (9). The cross-section area of element is  $500 \text{ mm}^2$  and  $E = 200 \text{ GPa}$ . Determine the nodal displacements, stresses in all members and reactions at support. 13

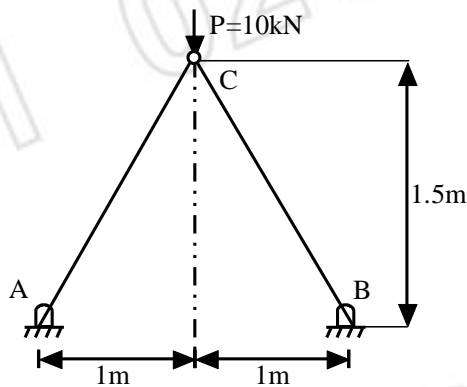

10. A two Dimensional triangular plate of thickness 15mm is shown in fig (10). Determine the nodal displacement. **13**

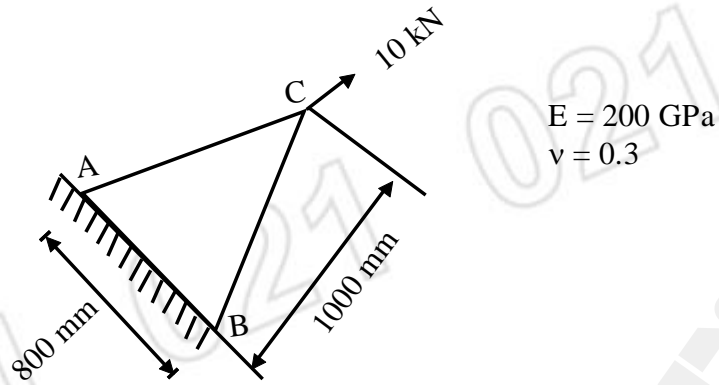

Fig. (10)

11. A simply supported beam of rectangular cross-section having distance between support 900 mm is subjected to load of intensity 1kN at midpoint of beam. Design the beam with following specifications. **14**
- Factor of safety =  $N = 1.6$ ,  
depth / breath (d/b) = 2.5,  
The depth 'd' should lie in between 15 mm and 150 mm. Solve the problem for minimum deflection for the following material  
SAE1030; SAE 1112 cold drawn; SAE4340  
Aluminium Alloy 260.
12. a) Explain in brief the various types of Modified optimization Design [MOD] problem. **4**
- b) A cantilever beam circular in cross-section is subjected to load of intensity 2kN at it's free end. The length of beam is 1000mm. The factor of safety is 1.5. Design the beam for minimum deflection for the materials AL-Alloy-260; SAE1030 and SAE4340. **10**

\*\*\*\*\*

